



3" Self-Priming Centrifugal Pump

Model: SE3SL-E6HCP

Price Code: P-58-13S4-E6HCP

Driver: Honda GX200 Series 196cc (5.5 HP)

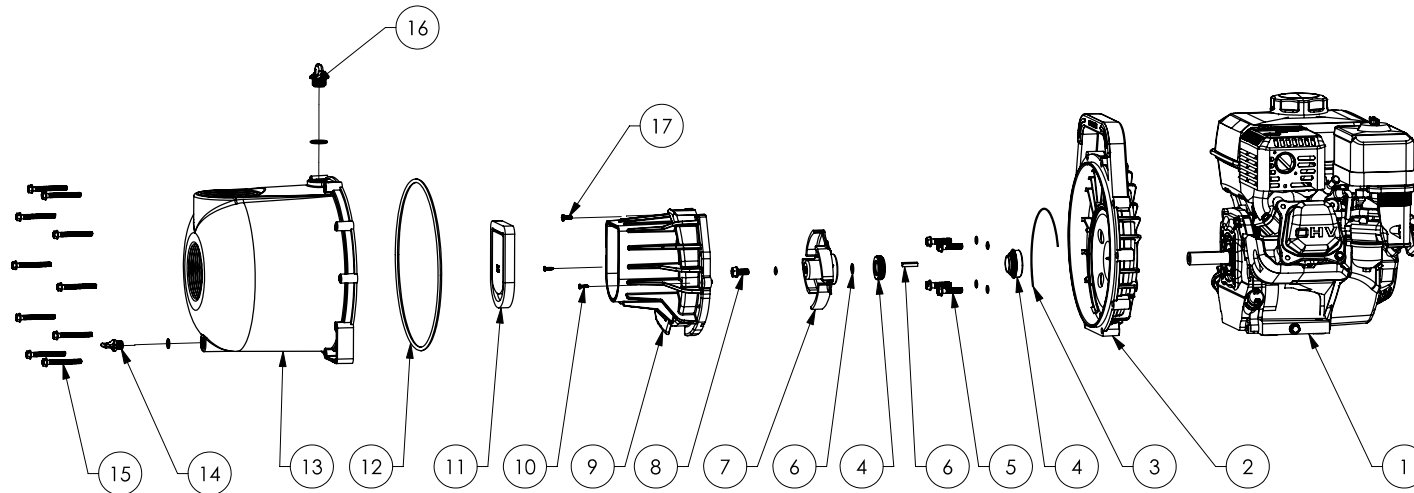
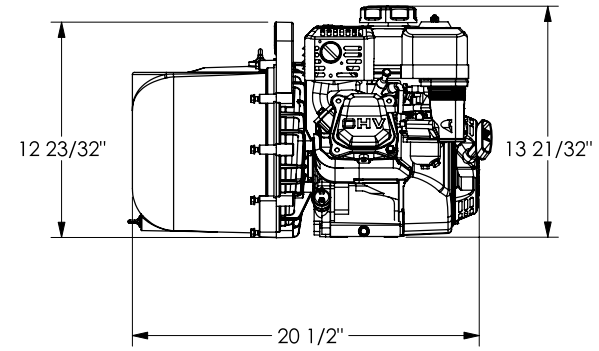
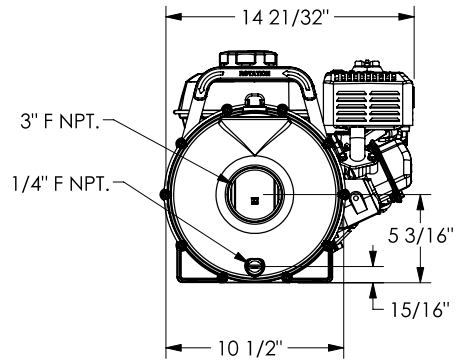



3" Self-Priming Centrifugal Pump

Model: SE3SL-E6HCP

Price Code: P-58-13S4-E6HCP

Driver: Honda GX200 Series 196cc (5.5 HP)

NO.	DESCRIPTION	QTY	PART NO.
1	Gasoline Engine Honda GX200 196cc	1	58-0647-H
2	Bracket PET	1	58-0703-30B
3	O-Ring Segment EPDM	1	58-0754-72
4	Shaft Seal EPDM, SS 316, carbon/ceramic 3/4"	1	58-0714-12
5	Bracket Screw and O-Ring SS 5/16-24x1 1/4" EPDM	4	58-0715-12
6	Key & Shim SS 3/16" Square x 15/16" Long	1	58-0778-S
8	Impeller PET 4 Vane, .975" Wide, ø4.75"	1	58-0975-30
9	Impeller Screw and O-Ring SS 5/16-24x3/4" EPDM	1	58-0716-12
10	Volute Flat PET	1	58-0977-30
11	Volute Side Screw SS 6-CCx1/2"	2	58-0725-10
12	Check Valve EPDM	1	58-0705-72
13	Body O-Ring EPDM	1	58-0719-72
14	Body PET, black 3" F NPT.	1	58-0755-30B
15	Drain Plug and O-Ring PET EPDM	1	58-0723-32
16	Body Bolt SS 18-8 1/4-20x2.125"	10	58-1206-10
17	Filler Plug and O-Ring PET EPDM	1	58-0722-32B
18	Volute Top Screw SS 10-24x.5"	1	58-0771-10